

+ INTERNAL COOLROOM PARTITION WALL

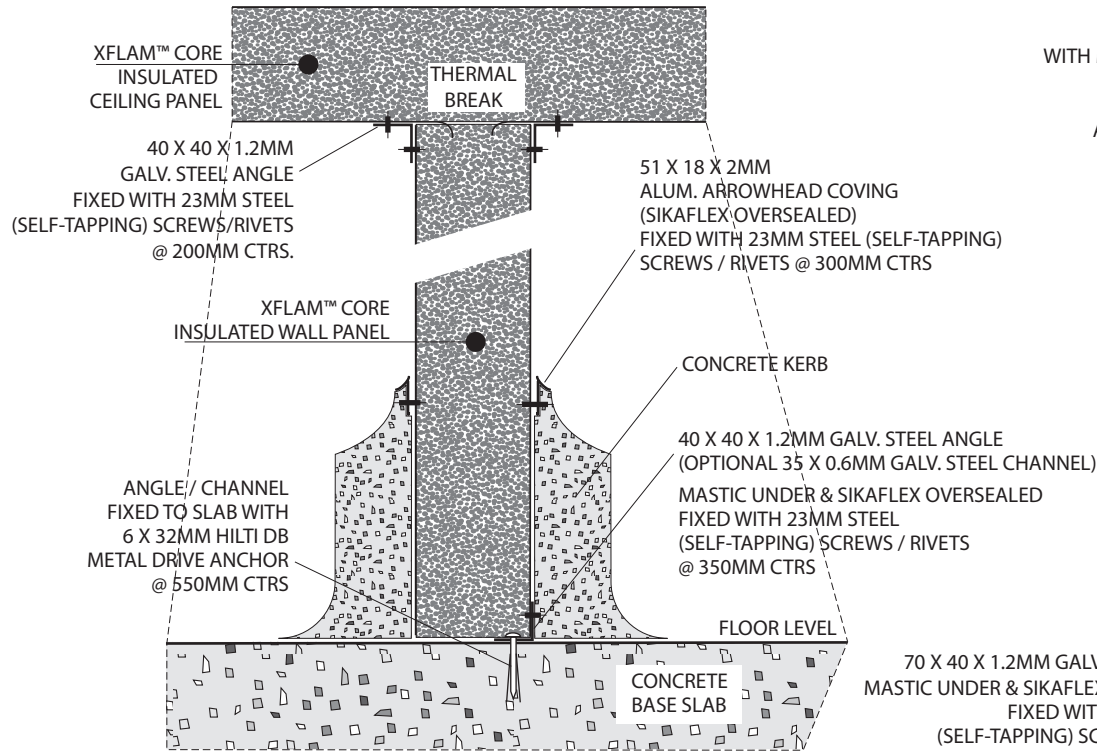

EXTERNAL

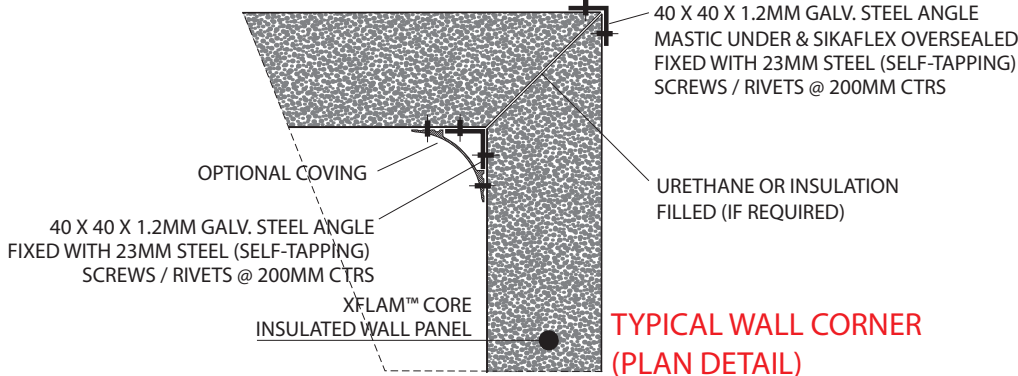

+ WALL PANEL SUPPORT

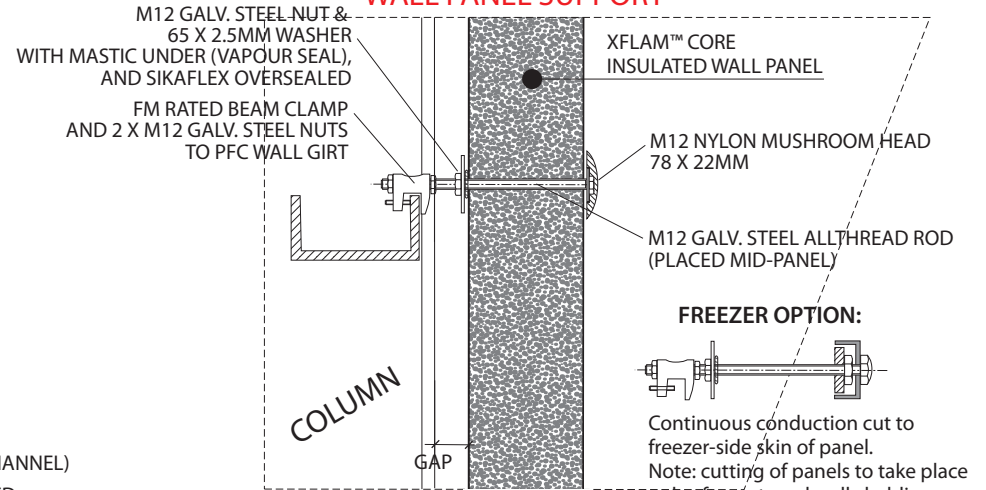

FREEZER OPTION:



Continuous conduction cut to freezer-side skin of panel.
Note: cutting of panels to take place only after external wall cladding has been fully completed on all walls.

70 X 40 X 1.2MM GALV. STEEL ANGLE MASTIC UNDER & SIKAFLEX OVERSEALED FIXED WITH 23MM STEEL (SELF-TAPPING) SCREWS / RIVETS @ 300MM CTRS

GRIPPLE HANG FAST SYSTEM

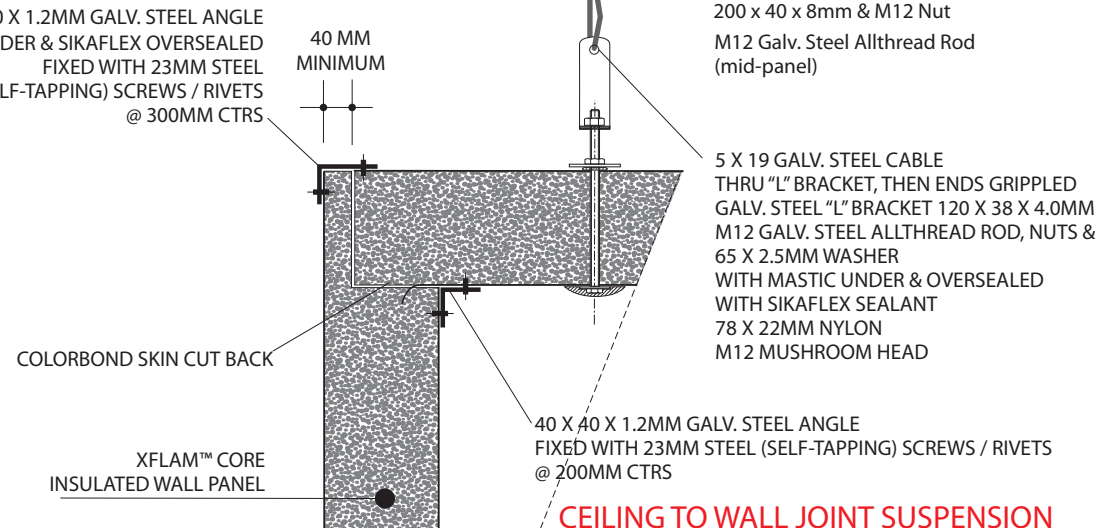

THIS DRAWING IS THE PROPERTY OF AUSTRAL INSULATION AND MAY NOT BE REPRODUCED IN WHOLE OR IN PART WITHOUT THEIR PRIOR WRITTEN CONSENT.

ALL COPYRIGHT RESERVED.

FIRE RATED DETAILS
XFlam™ Panel
WALL DETAIL



Drawn	SDH
Date	26.03.08
Rev.	31.07.08
Checked	
Drng. N°	C3